

LOC	DIST	REVISIONS					
AA	22	P	LTR	DESCRIPTION	DATE	DWN	APVD
		M		REDWN & REV; EC 0210-0111-95	5-11-95	GG	NJ

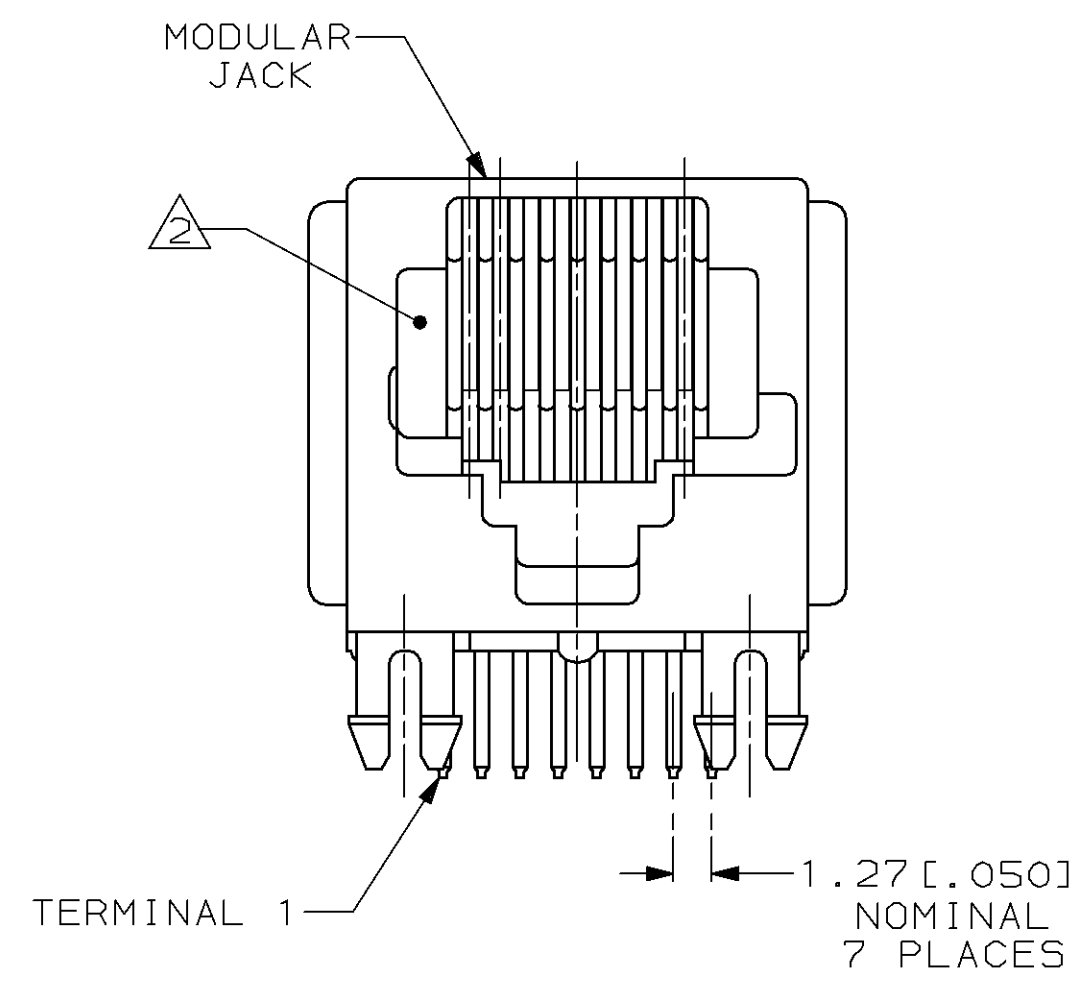

- 1. MATERIAL: HOUSING PBT POLYESTER, BLACK. TERMINAL-0.35 [.0138] THICK PH05-BRONZE PLATED WITH 1.27um [.000050] THICK HARD GOLD IN LOCALIZED GOLD PLATE AREA AND 2.03um [.000080] THICK TIN LEAD IN SOLDER AREA OVER 1.27um [.000050] THICK NICKEL UNDERPLATE.
- 2. CAVITY CONFORMS TO FCC RULES AND REGULATIONS PART 68 AND REA BULLETIN 345-81, PE-76 SPECIFICATION FOR MODULAR TELEPHONE HARDWARE.
- 3. ALL DIMENSIONS SHOWN ARE MAXIMUM UNLESS OTHERWISE SPECIFIED.

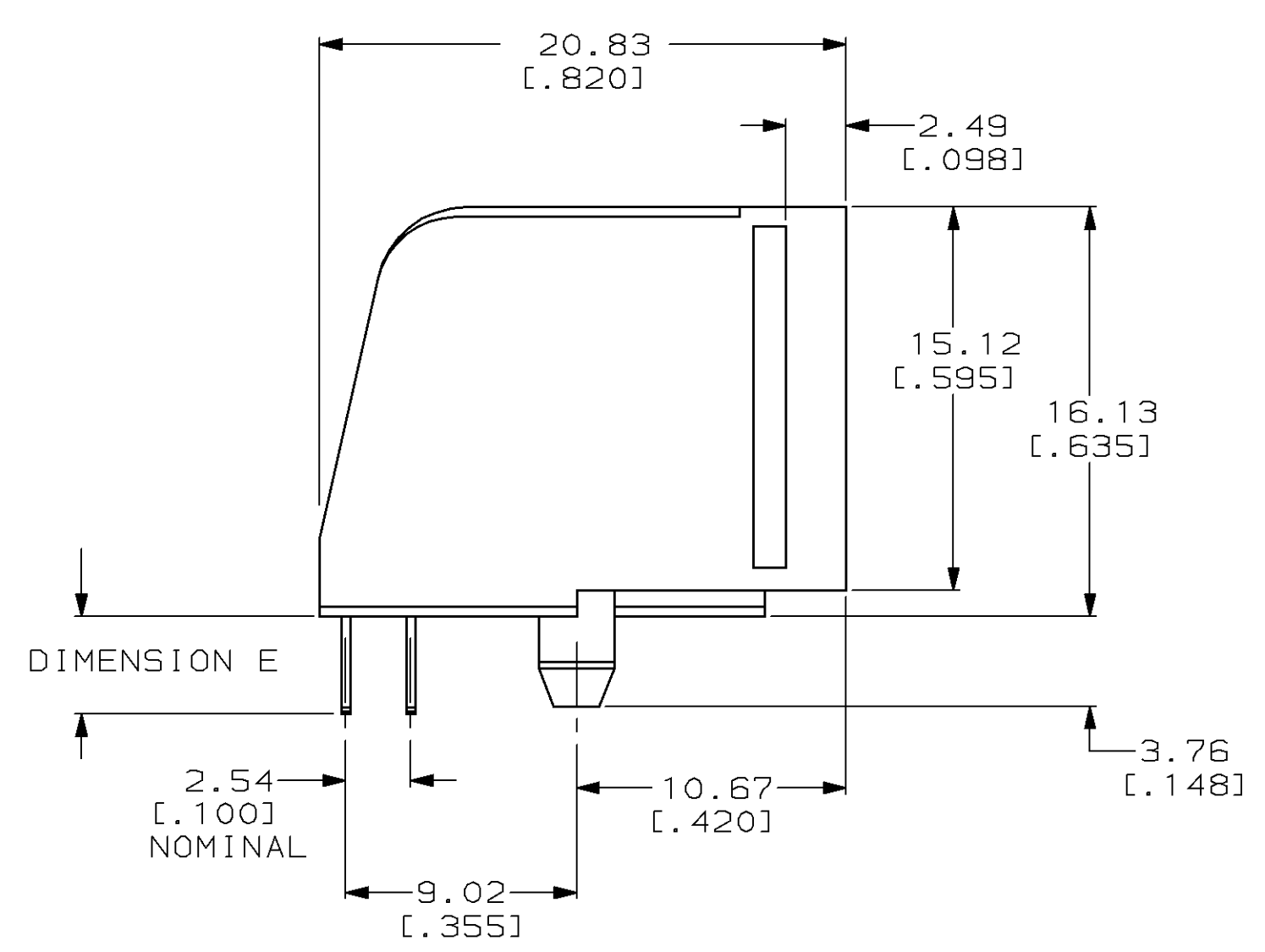
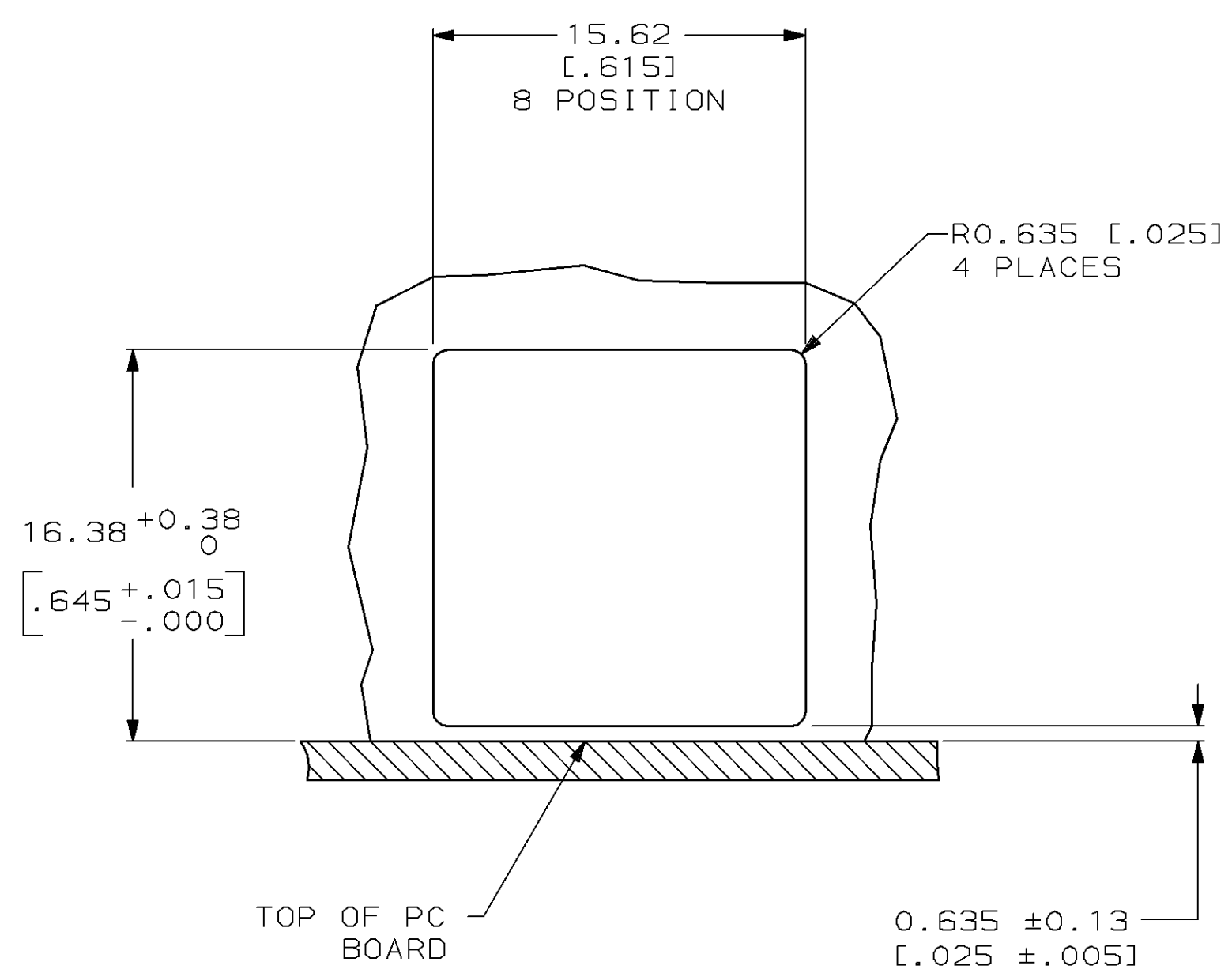
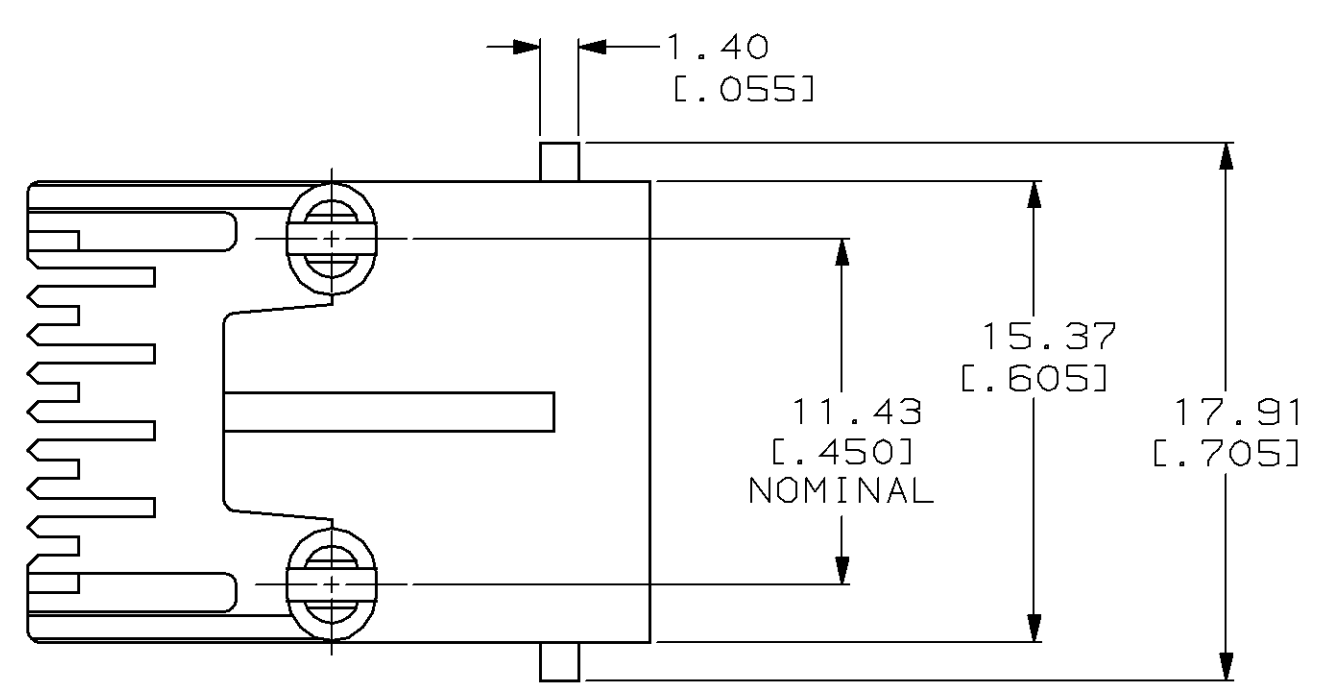

SUGGESTED PANEL CUTOUT

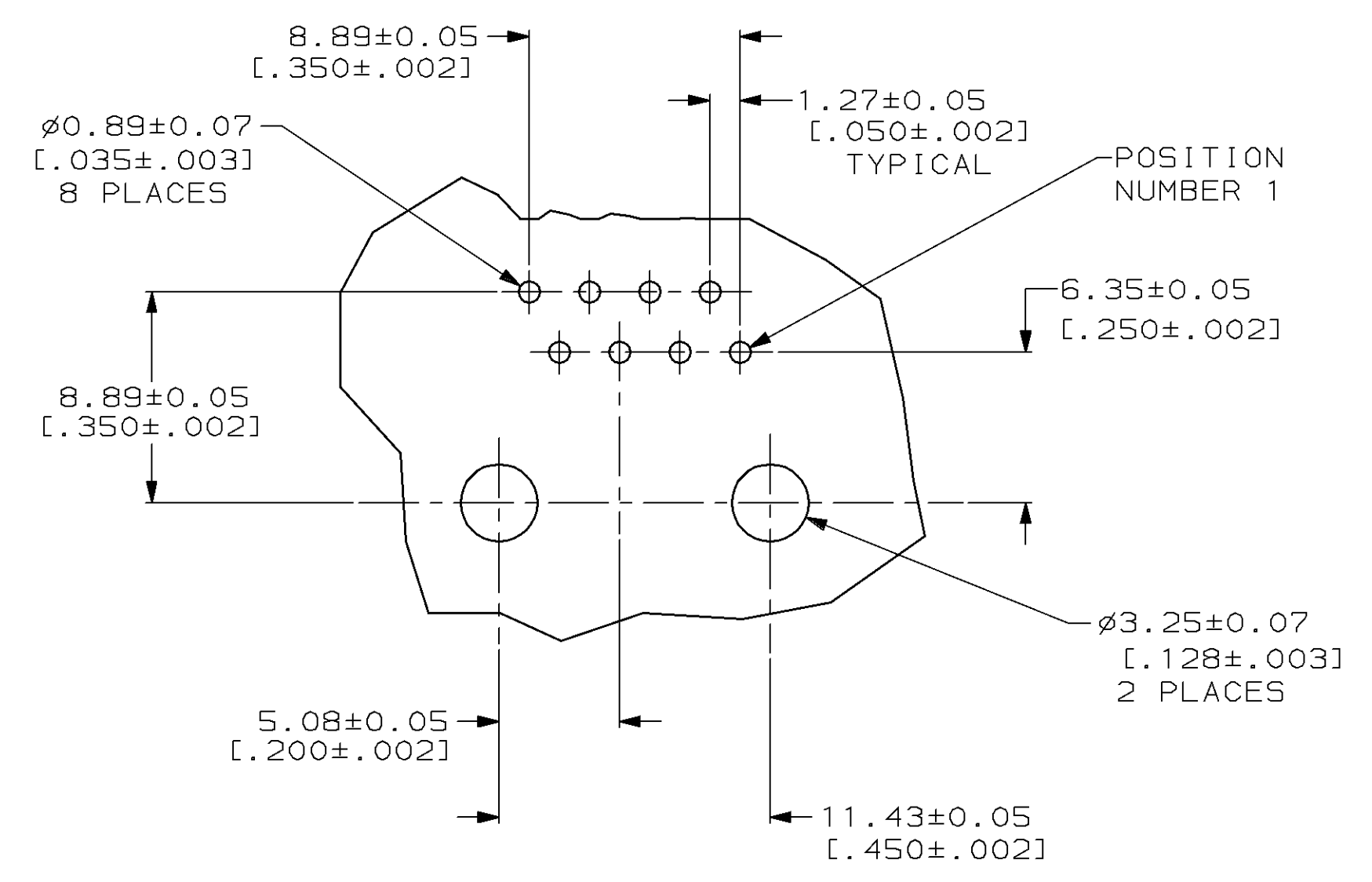

SUGGESTED PRINTED CIRCUIT BOARD LAYOUT
NONCOMPONENT SIDE SHOWN

DIMENSION E	CONTACTS	PART NUMBER
3.20 [.126]	8	520252-5
4.32 [.170]	8	520252-4

<small>THIS DRAWING IS A CONTROLLED DOCUMENT FOR AMP INCORPORATED. IT IS SUBJECT TO CHANGE AND THE CONTROLLING ENGINEERING DEPARTMENT SHALL BE CONTACTED FOR THE LATEST REVISION.</small>		DWN: G. GARRETT 05-11-95 CHK: N. JONES 5-23-95 APVD: E. LAUBER 5-30-95	AMP AMP Incorporated Harrisburg, PA 17105-3608
DIMENSIONS: MM (INCHES) 0 PLC ± 1 PLC ± 2 PLC ± 3 PLC ± 4 PLC ± ANGLES ± FINISH	TOLERANCES UNLESS OTHERWISE SPECIFIED: 0 PLC ± 1 PLC ± 2 PLC ± 3 PLC ± 4 PLC ± ANGLES ± FINISH	NAME: MODULAR JACK ASSEMBLY, SIDE ENTRY, 8 POSITION, KEYPED, FLANGELESS, WITH PANEL STOPS PRODUCT SPEC: 108-1163 APPLICATION SPEC: 114-2048 WEIGHT: - CUSTOMER DRAWING	SIZE: A1 CAGE CODE: 00779 DRAWING NO: 520252 SCALE: 4:1 SHEET: 1 OF 1 REV: M